

HotSense™ ultrasonic sensors for in-service wall thickness monitoring

Minimise operational risk and maximise productivity with enhanced asset intelligence

Ultrasonic transducers for 0° measurements ideal for thickness, corrosion and erosion monitoring for use in applications across **refining, oil & gas, energy, nuclear, aerospace** and **process sectors**.

Keywords: corrosion, erosion, in-service monitoring, hazardous environments, ultrasonics, high-temperature, radiation

ionix

ADVANCED
TECHNOLOGIES



HOTSENSE™

- **The original, truly high temperature transducer** powered by the Ionix HPZ piezo-ceramic.
- **Permanent or temporary installation** in the most extreme environments
- **-200 to +550 °C** [-328 to 1,022 °F] wide operating temperature range available for in-service, on-stream, monitoring applications
- **On-stream installation and calibration** with integrated reference block for reliable data
- **Highest sensitivity in class** for highest accuracy and precision in the most challenging installations
- **Intrinsically safe certified to Zone 0** for use in the most hazardous locations

DEPLOYMENT

- Install on live plant in minutes with a single tool
- No welding options for pipes - Ionix clamps are safe to use and can be readily removed
- Welded stud deployment option for vessels. Compatible with legacy stud mountings
- Standard transducer <50 mm total deployed height - install under insulation and weatherproofing to maintain your CUI defences
- Manual or automated data collection options available

SOLUTIONS

- Fixed UT sensors provide increased measurement precision & collection frequency for reliable and real-time corrosion trending supporting RBI & FFS programmes
- Optimise Asset Integrity and Performance Management (AIM/APM) programmes with accurate and reliable wall loss data
- Reduce operational costs and maximise production margins
- Data collection using standard UT flaw detectors with Measurement Hub
- Autonomous data collection and data direct to control centre wirelessly

hotsense  Powered by **ionix**

ix

HotSense™ 380



ISO 9001
Certified
ExVeritas®



STANDARD TRANSDUCER SPECIFICATION

PARAMETER	VALUE	UNIT
Operating Temperature	-200 to +380 / [-328 to +716] upto +550 [+1,022] on request	°C / [°F]
Delay Line Material	304 Stainless Steel - Passivated	-
Delay Line Length	25 / [1"] (up to 75 on request)	mm / [in]
Alternative delay line options on request		
Ruggedisation	Certified to IP 66/68 Stainless steel construction	-
Standard cable length	1 m MIMS + 2 or 15 m RG316	-
Connector Type	Lemo 00 receptacle	-
Acoustic characteristics certificate of conformity to ISO 22232-2 supplied with each unit		
Transducer Centre Frequency	3.25	MHz
-6 dB Bandwidth	80	%
Signal to Noise Ratio	>20	dB
For use with Measurement Hub manual and Caliperay automated monitoring solutions Also compatible with UT flaw detectors and thickness gauges		

Other variations available via special request
For other specification requirements please contact our sales team

STANDARD DEPLOYMENT SPECIFICATION

PARAMETER	VALUE	VARIABLES
Mounts/Clamp Materials	316 Stainless Steel - Passivated	-
Standard Pipe Clamp Sizes	NPS 2" to NPS 32"	Other sizes available on request
Standard Stud for Vessels	M8 x (40-60 mm)	
Standard Stud Spacing	52.5 +/- 5 mm	
Stud Torque Resistance	>20 N.m	
Total Mass (Deployed)	1.0 - 1.4 kgs	Dependent on deployment method

Flexible integration and monitoring system options. Can be used with a wide range of flaw detectors, local, remote or wireless data collections systems for WirelessHART, Cellular and LoraWAN.

Measurement resolution from 0.01 mm

Contact Ionix to order, for further information or to find a solution for your application

TYPICAL ULTRASONIC RESPONSE

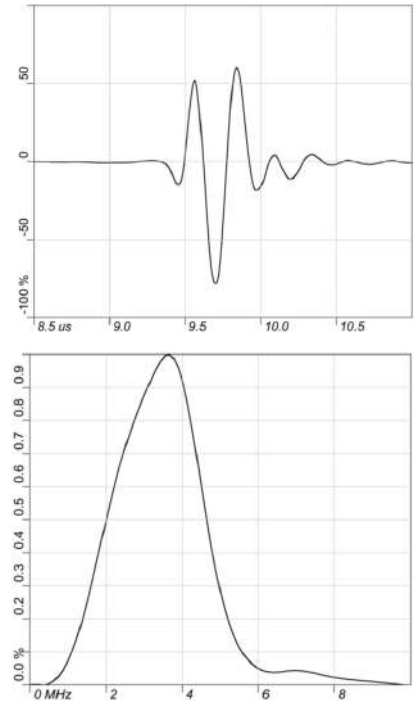

CERTIFICATION

Ex II 1 GD Ex ia IIC T* Ga / Ex ia IIIC T* Da
CE UK IP 66/68

To see HotSense™ in action or for hints & tips scan the QR code

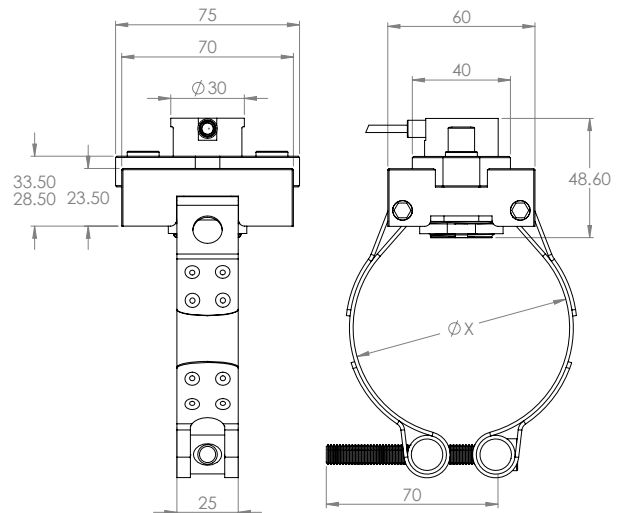

Want to discuss your demanding environment needs?

+44 (0) 1484 505859

contact@ionix.at

www.ionix.at

@ionix_at

ionix-advanced-technologies

@ionixadvancedtechnologies

